



Leer, Inc.
206 Leer Street, P.O. Box 206
New Lisbon, WI 53950
1-800-766-5337
www.leerinc.com

**ICE MERCHANDISER
INSTALLATION, OPERATION, AND SERVICE
MANUAL**



WARNING: This product can expose you to chemicals including nickel, which is known to the State of California to cause cancer (For more information go to www.p65warnings.ca.gov)

Table of Contents

Start-UP	3
Storage and Transportation:.....	3
Packaging:	3
Installation.....	3
Placing Merchandiser:	3
NSF Installation:.....	3
Merchandiser Leveling:.....	3
Electrical:.....	4
Condensate Evaporator:.....	4
Operation.....	5
Temperature Controls:.....	5
Mechanical Controls Thermostat:.....	5
Mechanical Controls: Defrost Timer:	5
Electronic Controls: Digital Display:	5
Operating Mode Display:	6
Electronic Control Operation:.....	6
Cold Wall Control:	6
Auto-Defrost Control:.....	6
Electronic Control Startup:	6
Possible Displayed Alarm Codes:	7
Loading Ice:.....	7
Maintenance	7
Cleaning the Merchandiser:.....	7
Cleaning Door Gaskets:.....	8
Cleaning Condenser Coils:	8
Defrosting the Merchandiser:	8
Cold Wall Defrost Methods:.....	8
Auto-Defrost Methods:.....	9
Auto-Defrost Mechanical Timer:	9
Auto-Defrost Electronic Control:	9
Glass Door Models and Maintenance:.....	10
Solid Door Models and Maintenance	10
Decaling Recommendations Solid Door:	10
Door Gaskets and Hardware:.....	10
Electronic Control- CW and AD Wiring Diagram.....	13
Mechanical Control- CW and AD Wiring Diagram.....	13
Replacement Parts List.....	14
Warranty.....	16

Start-UP

Storage and Transportation:

The merchandiser should be stored and transported in an upright position. It is not recommended to tilt the merchandiser. If the merchandiser is tilted beyond 45° of vertical, oil may drain from the compressor causing premature failure.

Do Not stack merchandisers on top of one another due to risk of falling. Falling merchandisers could result in damaged units or serious injuries. It is recommended to use warehouse racking design to accommodate the weight of the merchandisers and prevent falling.

Packaging:

Prior to installation, the outer packaging on the merchandiser will need to be removed. The majority of the packaging materials can be recycled and disposed of in an environmentally friendly manner. The wooden skid is secured to the underside of merchandiser with hex-headed screws and will require the use of a 3/8" hex-socket for screw removal. Glass door models are shipped with door support brackets installed between the merchandiser's door opening(s) and the bottom rail of the door. These support brackets need to be removed prior to operation of the merchandiser. Failure to remove the brackets will affect the seal of the door gasket to the cabinet face.

Installation

Note: Leer Merchandisers are commercial in design and not intended for residential use.

Placing Merchandiser: When placing the merchandiser, allow a minimum of 3 inches of air space from all surfaces of the cabinet and any surrounding structures. This air space allows for air flow over the surface of the cabinet, thus reducing condensation and aid in the drying of these surfaces. On outdoor auto-defrost models, the 3-inch space behind the merchandiser will also help ensure that the evaporator drain tube, which

exits the back wall, is not being restricted during the defrost cycle.

NSF Installation:

Most merchandisers can be special ordered with NSF certification. NSF merchandisers are supplied with leveling kits packaged inside. These kits are required by NSF to maintain a 6-inch clearance from bottom of unit to the ground. This kit must be installed on location. To install, use a proper lifting device to raise the merchandiser from the ground. Allow enough room to get the full kit under the skid plate. **DO NOT TIP THE MERCHANDISER** beyond 45° of vertical as mentioned in the **Storage and Transportation** section of this manual. Insert the stem of the leveling kit into the bottom of the skid plate. Lower the merchandiser into position while maintaining the 6-inch required NSF clearance.

Merchandiser Leveling:

The merchandiser installation location should have a solid, level base. If the merchandiser is exhibiting a slight forward lean, the front of the cabinet should be blocked to bring the cabinet to a level position. On auto-defrost models, a forward lean may negatively affect proper draining of the unit cooler assembly during the defrost cycle.

Leveling kits are available for use on most cabinet models. Contact the Merchandiser Sales Department for more information.



Full leveling kit shown, inserted into the skid plate of the merchandiser.

Electrical:

Warning! Component parts shall only be replaced with like components. Electrical and servicing should be done by licensed professionals. Disconnect power before performing service. Certain models contain multiple voltages. Leer does not assume responsibility for any damage to people or things deriving from violation, improper use or in any case not in compliance with Leer's instructions.

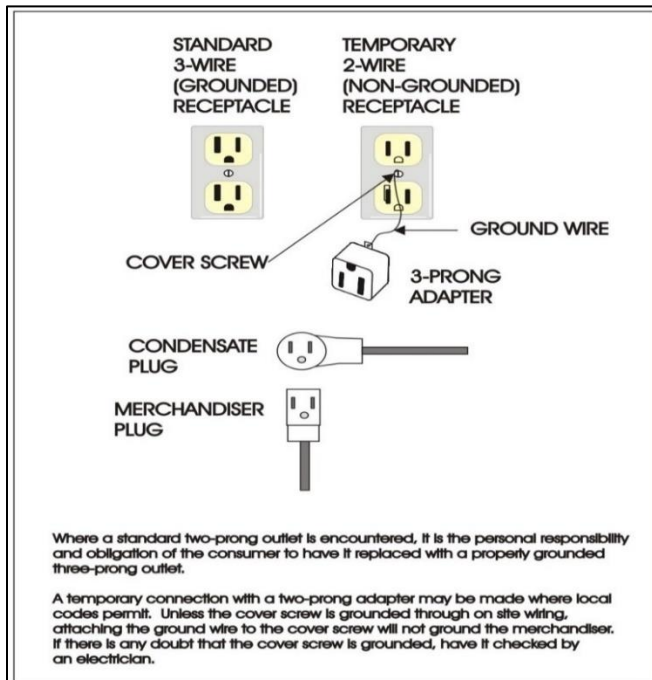

Figure 1: Grounding

The Merchandiser must be plugged into a dedicated and properly grounded 115V/60hz/1Ph circuit with a circuit fuse or breaker rated at a 15 or 20 Amps depending on model. The electrical service connections to the merchandiser must be compliant with national electric code and local codes that may apply. **DO NOT** use extension cords. The 20 Amp plug configuration, that some models come with, should **NOT** be removed. Some models are equipped with a main power switch. If so equipped, make sure the switch is in the OFF position before plugging the merchandiser into the lower receptacle of the electrical outlet.

WARNING: Operating more than one appliance on the same circuit may result in voltage

fluctuations when both appliances are operating simultaneously. This voltage fluctuation may cause the circuit breaker to trip and/or may cause voltage drops. As a result, the power to the merchandiser may be interrupted and freezing performance can be adversely affected which may cause equipment damage and /or product loss. Voltage supply to the merchandiser must not vary more than ± 10 percent of the normal 115V. Information regarding the electrical voltage and frequency being supplied to the merchandiser can be found on the merchandiser's serial data plate typically located at the upper left corner of the merchandiser's interior. Information regarding the maximum fuse/circuit breaker size required for the specific model is available from the condensing unit data plate.

Condensate Evaporator: Indoor auto-defrost models are supplied with a condensate evaporator heater assembly which is packaged with instructions and shipped inside the merchandiser. It will require simple installation by the consumer (see Figure 2). A separate copy of this instruction sheet is supplied with the condensate evaporator assembly. The condensate evaporator assembly contains a drip pan to collect water generated by the merchandiser's defrost cycle and a heat element to evaporate the water. Once energized, the heat element in the condensate evaporator assembly is continuously generating heat. The merchandiser is to be placed so that there is at least 1 inch of air space between the back surface of the condensate evaporator housing and any wall surface behind the cabinet which allows for heat dissipation away from the surface of the wall. The main power cord should also be routed to avoid pinching.

Note: Do not operate an indoor auto-defrost merchandiser without having a condensate evaporator assembly installed under the evaporator drain tube exiting the back wall of the cabinet. Failure to install this assembly will result in water draining directly onto the floor during the defrost cycle. This may result in water damage to the floor and create a hazardous slip condition in the area surrounding the merchandiser.

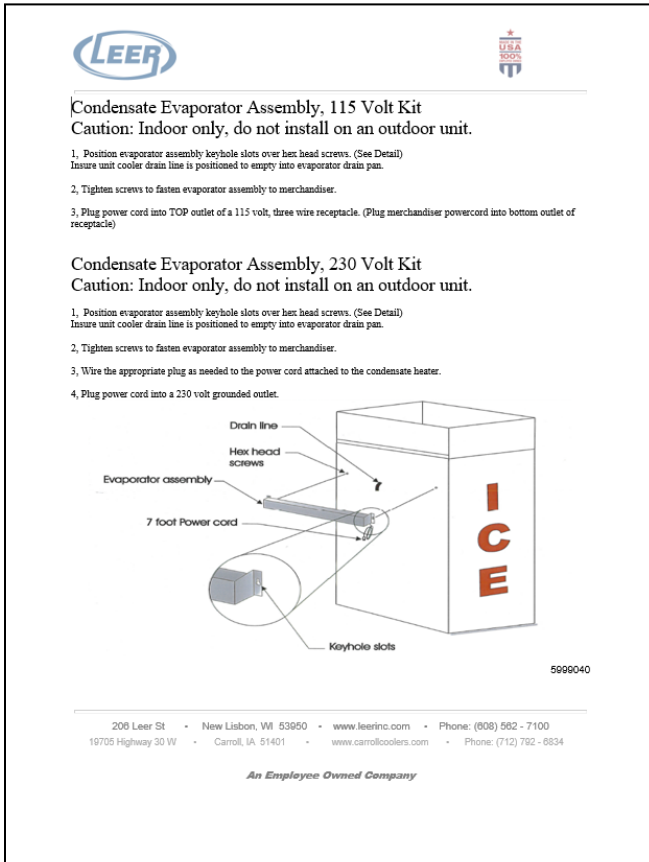

Figure 2: Condensate Evaporator Installation

Operation

Temperature Controls: Merchandisers are currently available with either mechanical controls (optional) or an electronic control (standard).

Mechanical Controls Thermostat:

The compressor is controlled by the classic thermostat where the engagement and disengagement of the thermostat is controlled by the expansion and contraction of gas within a sensing tube. Merchandisers with mechanical thermostats are factory set to operate at a cut-out temperature of 18° F +/-2°. The thermostat has an adjustment knob that allows a limited adjustment range. Rotating the adjustment knob clockwise will lower the cabinet temperature while a counterclockwise rotation will raise the cabinet temperature. Rotating the adjustment knob fully counter-clockwise will shut off power completely to the merchandiser’s condensing unit. The

thermostat has a pre-set differential of 7° F, which is not adjustable.

On cold wall (CW) cabinet models, the thermostat is located on top of the cabinet under the condensing unit cover housing. The sensor tube inserts through the ceiling of the cabinet and exits near the interior back wall.

On automatic defrost (AD) cabinet models, the thermostat is housed inside the unit cooler assembly that is mounted to the interior ceiling of the cabinet.

Mechanical Controls: Defrost Timer:

The defrost timer is located under the condensing unit housing. The timer will engage the merchandisers defrost cycle once every 4 hours for a duration of 16 minutes. The standard timer, supplied with most merchandisers, is pre-set and non-adjustable. The timer may be manually advanced into defrost by rotating the advancement knob in a clockwise direction. The knob is located on the rear of the timer casing. Manual advancement into the defrost mode will re-set the next controlled defrost cycle to take place in 4 hours.

The automatic defrost function is available on cabinet models designated as “auto-defrost” (AD). The cold wall (CW) cabinet models do not have an electronically controlled defrost and require manual de-icing of the cabinet’s interior walls.

Electronic Controls: Digital Display:

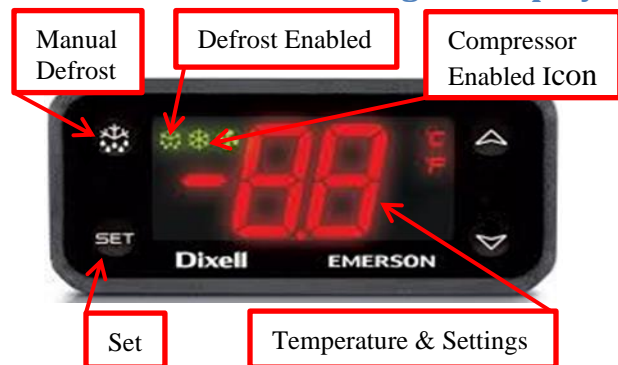

Operating Mode Display:

- Snowflake “ON” – compressor enabled in run cycle; control displays current cabinet temperature.
- Snowflake “Flashing” – anti short cycle delay enabled to protect the compressor from trying to start too frequently.
- Melting Snowflake “ON” – defrost in progress, control displays the letters “DE”
- To view the control’s programmed “Set Point” (cut-out temperature): press and release the “Set Key.”
- To initiate a manual defrost cycle: press and hold the “Manual Defrost Key” for more than 2 seconds.

Note: Manual Defrost will not initiate unless the unit is at standard operating temperatures.

Electronic Control Operation:

The electronic control combines the functions of both the mechanical thermostat and defrost timer into a single control. The control also offers the consumer the capability of monitoring the operational status of the merchandiser via the icon and digital temperature display (located on the face of the control). The controller has been programmed by Leer to operate the merchandiser within the design parameters of the refrigeration system. The set-point (cut-out) for these controls has programmed parameters for 16°F, with a differential of 8°F. Should the user desire to alter the Set-Point, the new set-points should not exceed +/- 4° of the original factory setting. Do not alter any of the programming parameters in the controls without first consulting with Leer. There are two separate electronic controls available based upon the cabinet type; Cold Wall or Auto-Defrost.

Cold Wall Control: The CW control is located under the condensing unit housing. The control has a single thermal-couple probe wire used to monitor the air temperature inside the cabinet. The probe enters through the top of the cabinet and is secured at a specific location where the back wall and ceiling of the interior meet. The control will display the air temperature in the cabinet at the probe’s location. Although the control has a Manual Defrost Key, this action is

non-functional on the CW cabinet models (see the defrost instructions for CW cabinet models in the “**MAINTENANCE**” section of this manual).

Auto-Defrost Control: The AD control is also located under the condensing unit cover and contains two thermal-couple probe wires. Both probe wires are routed through the cabinet’s suction line hole and into the unit cooler assembly, which is mounted to the interior ceiling of the cabinet. The Red Air Sensing Probe (“P1”) routes through the unit cooler and has its’ sensing bulb secured to the outer, left-hand wall of the unit cooler. Probe “P1” monitors the air temperature in the merchandiser at that location. During the normal operation of the control, the digital display will show the cabinet temperature at the probe “P1” location. The Black Probe “P2” is inserted into the finned section of the evaporator coil, near the top of the unit cooler assembly. This probe monitors the temperature of the evaporator coil during the defrost cycle.

Electronic Control Startup: Turn the switch if equipped into the ON position. **After a 2-minute delay, the compressor and the condenser fan should start.** The evaporator fan motors and the light fixture will operate immediately when power is applied. The condensing unit will continue to run until the air temperature in the cabinet reaches +16°F.

Note: If a defrost is required upon startup the controller will enter defrost mode after the 2-minute delay. Normal operation will resume upon defrost termination and a short drip time.

Possible Displayed Alarm Codes:

“P1” – Air Probe failure: The control will override the “P1” functions and cycle the compressor at 5-minute intervals, until the probe fault can be corrected.

“P2” – Evaporator Probe failure: The control will override the “P2” function and operate with a timed defrost cycle, until the probe fault can be corrected.

“HA” – Maximum Temperature Alarm: The cabinet air temperature has exceeded programmed temperature for a period exceeding 15 minutes. The alarm will continue to display until the cabinet temperature drops below maximum levels.

“LA” – Minimum Temperature Alarm: The cabinet air temperature has dropped below the programmed minimum. This alarm will continue to display until the cabinet temperature rises above the minimum level.

Note: Should a “P1” or “P2” alarm occur, check the probe wire connections to the control prior to replacing the probe wire.

For more information regarding the electronic control program and instructions, please contact: Leer, Inc. Merchandiser Division Customer Service. Phone: 800-766-5337 or our web-site at <https://www.leerinc.com>

Loading Ice: The merchandiser should be pre-chilled prior to loading with ice. Pre-chilling will aid the merchandiser in reaching storage temperature at a faster rate once loaded and reduce the risk of melting product. Do not over fill the merchandiser with ice!

Cold Wall Models: If the bagged ice blocks off air flow from the front of the cabinet to the control’s air probe, the control may not respond quickly enough to maintain proper cabinet temperature. Allow a minimum of 6 inches clearance between the top of the ice stack and the ceiling of the cabinet interior. This distance will allow a pathway for warmer air entering the cabinet

during door openings to migrate to the sensing bulb on the probe.

Auto-Defrost Models: Avoid stacking ice above the top edge of the air ducts that are installed on the walls of the cabinet interior. Blocking off these air ducts may restrict the even distribution of cold air throughout the cabinet, this may result in warm spots developing within the cabinet. Also, do not stack ice high enough to block off the evaporator fans in the unit cooler assembly. The evaporator fans are intended to pull warm air entering the cabinet into the unit cooler and then push that warm air across the surface of the evaporator coil. This process removes the heat prior to distributing the air into the cabinet.

Maintenance

Note: Component parts shall only be replaced with like components. Maintenance and repair of the electrical and refrigeration systems should only be done by trained and qualified personnel. Disconnect power before performing service. Certain models may contain multiple voltages. Leer does not assume responsibility for any damage to people or things deriving from violation, improper use, or in any case not in compliance with Leer’s instructions.



Cleaning the Merchandiser: The merchandiser should be cleaned annually. In corrosive environments such as coastal regions and areas where deicing chemicals and road salts are used, more frequent cleaning is recommended. The exterior of the merchandiser can typically be cleaned with the use of detergents diluted in warm water followed with a tap water rinse. The exterior paint is capable of withstanding the use of polishing compounds and most solvents. If using stronger cleaning agents, they should be tested on a small, inconspicuous areas prior to application

onto visible surfaces of the merchandiser. If cleaning the interior of the merchandiser, the use of detergents with strong odors (i.e. citrus based cleaners, abrasive cleaners containing chlorine bleach, and any form of solvent based cleaners) are not recommended. They may leave objectionable odors inside the cabinet which may be absorbed by the ice being stored in the merchandiser.

Cleaning Door Gaskets: Door gaskets may mildew and stiffen over time. The gasket is made of a soft, flexible rubber-like material that can be cleaned using most kitchen and bath cleaners designed for mildew removal. Review manufacturer information and instructions on any cleaning agent prior to use to determine the cleaner's compatibility with the surface being cleaned.

Cleaning Condenser Coils:

It is recommended to inspect and clean the condenser coil and fan blades every 3 months. There are a variety of methods available for cleaning the condenser coils. Keep in mind that the debris is being drawn into the coil by the condenser fan and the debris should be removed in the opposite direction.

- The simplest and preferred method would involve the use of a vacuum cleaner to suck the debris out of the coil from the outside surface.
- Another method is using compressed air to blow dust from the coil. The debris should be blown out from the inside surface of the coil.

WARNING: When using compressed air, there may be a cloud of dust released into the air surrounding the machine.

It is recommended that the service person wear proper protective equipment (i.e. safety glasses and a dust mask) when performing coil cleanings.

Note: DO NOT use any type of filter media in front of the condenser coil to trap dust. Filter testing has proven to create enough restriction of air flow to reduce the efficiency of the coil's heat exchange.

Defrosting the Merchandiser:

The Auto Defrost merchandiser is designed to be self-defrosting. The heat generated by the defrost heater element will melt the ice build-up on the evaporator coil and the resulting water will drain through a tube out of the back wall of the machine.

It is recommended to check the operation and condition of the evaporator coil and for signs of excessive ice buildup every 3 months

The means and methods of the ice removal are dependent upon whether the merchandiser is a Cold Wall model or an Auto-Defrost model.

Cold Wall Defrost Methods: The evaporator tubing for the cold wall cabinet models are located within the walls of the cabinet. After the cold wall merchandiser is energized, a visual inspection of the cabinet's interior will reveal a serpentine frost pattern developing on the ceiling and walls. This frost pattern represents the configuration of the evaporator tubing as it's attached to the inside surface of the cabinet. As humidity enters the cabinet, it will collect and accumulate along this frost-line pattern. As the frost-line expands and builds in thickness, it will slow the heat transfer between the cabinet walls and the evaporator tubing. The cold wall cabinet models do not have the design capability to self-defrost. In order to defrost the cold wall models, product will need to be emptied from the cabinet and the power to the cabinet disconnected. Defrosting requires the entire interior surface of the cabinet to be warmed above freezing in order to melt and remove the build-up of ice from the interior surfaces.

Power to the merchandiser can be turned off by merely unplugging the cabinet from its power source. If the merchandiser is equipped with a mechanical thermostat, power can also be turned off by rotating the temperature adjustment knob to its full counterclockwise position. After the defrost operation is complete, return the knob to its normal position to re-energize the condensing unit. If the cold wall cabinet has an electronic control, power can also be turned off by use of the ON/OFF toggle switch located on the control box of certain cabinet models. If the toggle switch is not present on the control box, the only means of disconnecting power is to unplug the main power cord at the power source. Although the electronic control on the CW merchandiser has a defrost key on its display face, this feature does not function with the CW cabinet design and **will not** switch off power if pressed.

With the merchandiser de-energized, the defrost process can be expedited with the addition of hot air

being forced through the cabinet's door opening(s). As the ice build-up softens, a plastic ice scraper may be utilized to aid in the removal of ice from interior of the cabinet. If possible, avoid the use of metal ice scrapers, ice picks, or hammers as these tools may inadvertently penetrate through the wall of the cabinet, puncture the evaporator tube, and cause irreparable damage.

A floor drain is present in most merchandiser models. For outdoor models, the floor drain plug can be removed to allow water drainage. If draining to the ground is not desirable or if the merchandiser is located indoors, the water may be removed with the use of a wet-vac and disposed of. It is suggested that some of the time allocated to defrost the cold wall cabinet may be utilized for the cleaning of the condenser coil as well as inspecting the condition of wiring insulation, door gaskets, and spring-loaded hinges.

Auto-Defrost Methods: Auto-Defrost models are equipped to be self-defrosting and enter defrost mode once every four hours automatically. During the defrost cycle, the power to the refrigeration system will be automatically re-directed to the defrost circuit. This will shut down power to the condensing unit, evaporator fan motors and also send power to a heat element that is attached to the surface of the evaporator coil. The heat generated by the element will melt the ice build-up on the evaporator coil and the resulting melt water will drain through a tube out of the back wall of the merchandiser.

On outdoor cabinet models, the melt water will exit the drain tube directly to the ground.

On indoor cabinet models, the consumer needs to install the condensate evaporator heater assembly (described in the **Installation** section of this manual) onto the exterior back wall of the cabinet. The melt water from the defrost cycle will drain into a catch pan where it will then be heated to the point of evaporation. The function of the condensate evaporator's heat element should be checked routinely. Failure of the element could result in an over-flow condition for the assembly's drain pan. A simple check of the heater would be a touch test of the surface temperature of the assembly's housing. The condensate evaporator's heat element is energized continuously so the surface of the housing should always be hot to the touch. If testing the heat element with a meter, the element can be unplugged from its power source and a resistance reading can be taken through the plug's bladed terminals. The condensate heater is rated to generate 125 watts of power, which translates to approximately 106 ohms of resistance.

Auto-Defrost Mechanical Timer: The AD merchandiser may come equipped with a mechanical timer (as described in the **Operation** section of this manual). The timer is factory set for a 16 minute defrost cycle to occur at 4-hour intervals. During its run-cycle, the timer supplies power to the thermostat, condensing unit, and evaporator fan motors. During the defrost cycle, the timer switches power from the run-circuit to the defrost-circuit and energizes the defrost heater. The AD mechanical timer may be manually advanced to a defrost mode by rotating the advancement knob (located on the back of the timer) in a clockwise direction until the defrost switch engages. The advancement knob rotates in a clockwise direction only.

The mechanical defrost circuit is equipped with a defrost termination switch and is attached to one of the evaporator coil tubes (located inside the Unit Cooler Assembly). This switch senses temperature and will cut power to the defrost heat element should the temperature at the surface of the switch reach 70° F. This switch terminates power to the heat element and will not end the timed defrost cycle. Once the unit has returned to run mode, the termination switch will reset when the temperature at its surface reaches 30° F.

Auto-Defrost Electronic Control: For Merchandisers with an electronic control (as described in the **OPERATION** section of this manual). The timer is factory set for a 24 minute defrost cycle to occur at 4-hour intervals. Like the mechanical timer, the electronic control will switch power from run mode (condensing unit and evaporator fans) to defrost mode (defrost heat element). Whereas the mechanical timer operates strictly on a timed cycle, the duration of the electronic control's defrost cycle is controlled by the temperature at the sensor probe "P2." If the temperature at this probe reaches 60°F prior to the 24-minute timed cycle ending, the control will override the timed cycle and immediately switch power from the defrost mode to a drip time then standard run mode. If temperature is not reached at probe "P2," the defrost cycle will continue for the entire 24- minute programmed cycle prior to returning to run mode. Energizing the defrost circuit in the electronic control can be verified with the illumination of the "melting snowflake" and the letters "DE" appearing on the control's display.

The electronic defrost circuit is equipped with a defrost termination safety switch and is attached to one of the evaporator coil tubes (located inside the Unit Cooler Assembly). This switch senses temperature and

will cut power to the defrost heat element should the temperature at the surface of the switch reach 100° F. This switch only terminates power to the heat element and will not end the timed / temperature defrost cycle. Once the merchandiser has returned to run mode, the termination safety switch will re-set when the temperature at its' surface reaches 70° F.

Warning! The defrost termination / safety switch functions as a possible fire protection device. Do not remove or by-pass the switch from the defrost circuit.

Note: If an electronic control AD unit loses power and the temperature at "P2" is less than 60°F, it will automatically enter a defrost cycle after a two-minute delay.

Glass Door Models and Maintenance:

The glass door is designed for use on indoor units or in a controlled environment. It is constructed with a non-heated, triple-pane glass-pack, with both inner and outer panes being tempered. To avoid possible condensation on the outer surface of the door, case temperature in the merchandiser should be maintained near its' designed set-point of 16°F +/- 4° and ambient dew-points around the cabinet location should be kept below 60°F. Any household glass cleaner can be used to clean the surface of the door. The glass door's gasket is a rubber bellows-style magnetic gasket. The replacement gasket has an insert dart that installs into a retaining slot in the door frame. The gasket can be started in-place with light hand pressure, followed with mild impact pressure applied with a dead-blow hammer to ensure that the legs of the dart penetrate fully into the slot. During replacement, always set the gasket at the 4-corners of the door first to reduce stretching the gasket. If the door gasket appears to be in good condition but is failing to seal to the surface of the cabinet, both the spring-load tension and adjustment of the hinges should be checked.

A simple test of the spring-load tension is to open the door just enough to insert two fingers between the surface of the cabinet and the handle side of the door. When the fingers are withdrawn, there should be enough tension set on the hinge spring-loads to slowly move the door to a closed position. If the door does not move from this two-finger location, it's likely that either the spring-load requires re-tensioning or lubrication. If the door moves part way from the two-finger location but stops short of the cabinet, the compression of the gasket along the hinge side of the door should be checked. If there is too much compression, the door will bind when closed and

should have its hinge-mount location checked and possibly adjusted. Removing the hinge covers will expose the spring-loads for tension adjustment or removal. Removal of the spring-load will expose the hinge-adjustment plate and mounting screws should hinge adjustment be required. See **Figure 3** for instruction regarding spring-load installation and adjustment.

Solid Door Models and Maintenance:

Cabinets designed for outdoor use will have a metal clad door that has been insulated with the same urethane foam insulation as the cabinet. The exterior metal is stucco embossed to hide minor impacts and is coated with a fluorocarbon paint system. This paint system was designed to withstand years of outdoor exposure. For routine cleaning of the door's exterior surface, a mild detergent diluted in warm water should be adequate.

Decaling Recommendations Solid Door:

- a) Use a decal with a 2-mil cast vinyl substrate. Cast vinyl contains less memory than a calendared vinyl or a polyester substrate and will conform to the embossed surface with the least amount of stress on the decal's adhesive.
- b) The decal's adhesive should have a minimum peel-strength rating of 80 oz. /inch.
- c) Clean the surface of the door with isopropyl alcohol and either air dry or dry with a clean cloth.
- d) Heating the surface of the door immediately before applying the decal will aid the adhesive bond of the decal. Never apply a decal to a surface that is colder than 50° F.
- e) Use a soft roller or plastic squeegee to apply the decal and press it into the embossed surface of the metal. Applying a small amount of heat to the surface of the decal will aid in this process.

Door Gaskets and Hardware:

Routine inspection of the door gasket seal and the action of the door's hinges are recommended. If damage has occurred to the gasket, it may allow outside air to penetrate the cabinet and the gasket should be replaced. The upright solid door (measuring 27" x 46") utilizes the same hinge as the glass door. The slant door (measuring 27" x 27") utilizes a hinge which is not spring-loaded. Both doors have the same gasket profile, which has a barbed dart that inserts into a slot opening in the surface of the door frame. See **Figure 4** for instructions on solid door gasket replacement.

SPRING CARTRIDGE INSTALLATION INSTRUCTIONS

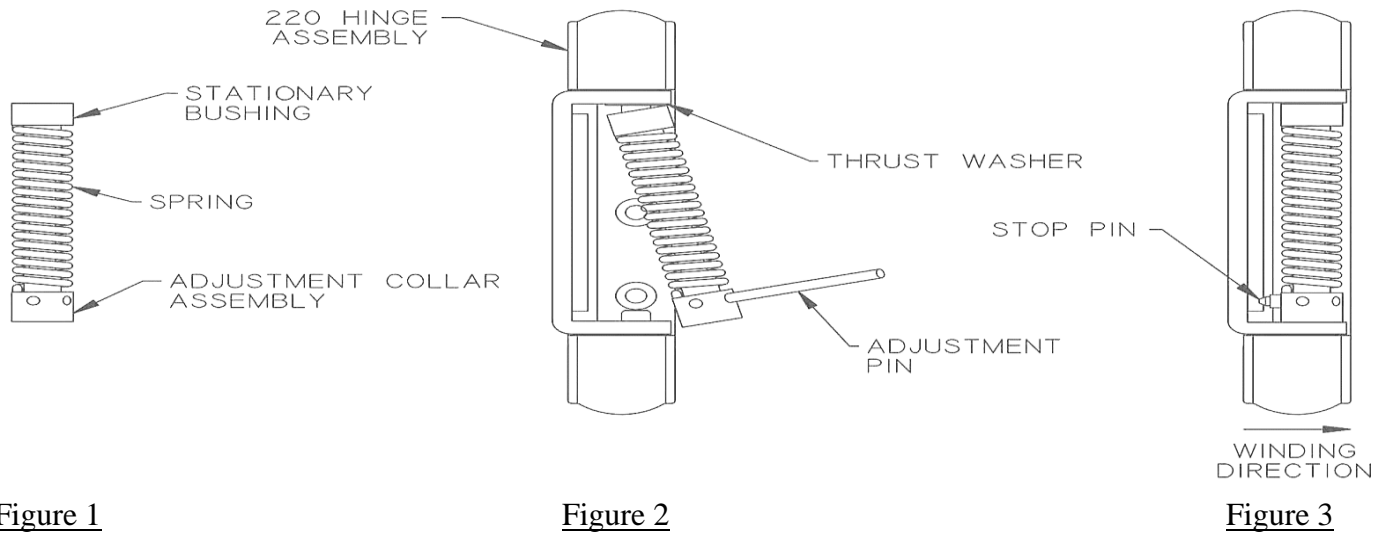

Figure 1

Figure 2

Figure 3

- 1) Install No. 220 Hinge with Adjustment Plate.
- 2) Assemble Spring Cartridge. Grease bushing end of pin prior to insertion into Stationary Bushing. Apply a small amount of grease to the hinge-pin hole on the end of the Adjustment Collar Assembly. (Fig. 1).
- 3) Place Thrust Washer and Stationary Bushing over square pin in the Hinge and insert the Adjustment Pin into the Adjustment Collar. Using the Adjustment Pin, compress the Spring and place the Adjustment Collar over the round pin (Fig. 2).
- 4) Using the Adjustment Pin, turn the Adjustment Collar until the Pin contacts the Hinge. Then insert the Stop Pin in hole of Adjustment Collar (Fig. 3). **CAUTION:** The Stop Pin must fully seat on Adjustment Collar. Failure to do so may cause the Stop Pin to become dislodged. Inserting the Adjustment Pin more than halfway thru the Adjustment Collar can cause partial push out of the Stop Pin. Repeat adjustment until desired tension is reached. The maximum tension is 6 holes or approximately 1-1/4 turns.
- 5) Install Cover on Hinge.

WARNING: Use safety glasses when installing and adjusting spring tension.

Figure 3: Spring Install Instructions

Solid Door Magnetic Gasket Replacement Instructions:

1. Position solid door on a flat non-abrasive surface, exterior side down.
2. Remove old gasket by grasping firmly at the corner and pulling away from the door frame extrusion.
3. Inspect the extruded slot to insure there are no particles to interfere with the new gasket installation.
4. Align new gasket with door corners and use thumb to press into frame.
5. Start at one corner of the frame and begin pressing the new gasket into the slot. Using a non abrasive tool such as a hammer head works well for this application. Apply downward pressure while moving along the perimeter of the frame. Excessive pressure may stretch the gasket and cause bulging at the corners.

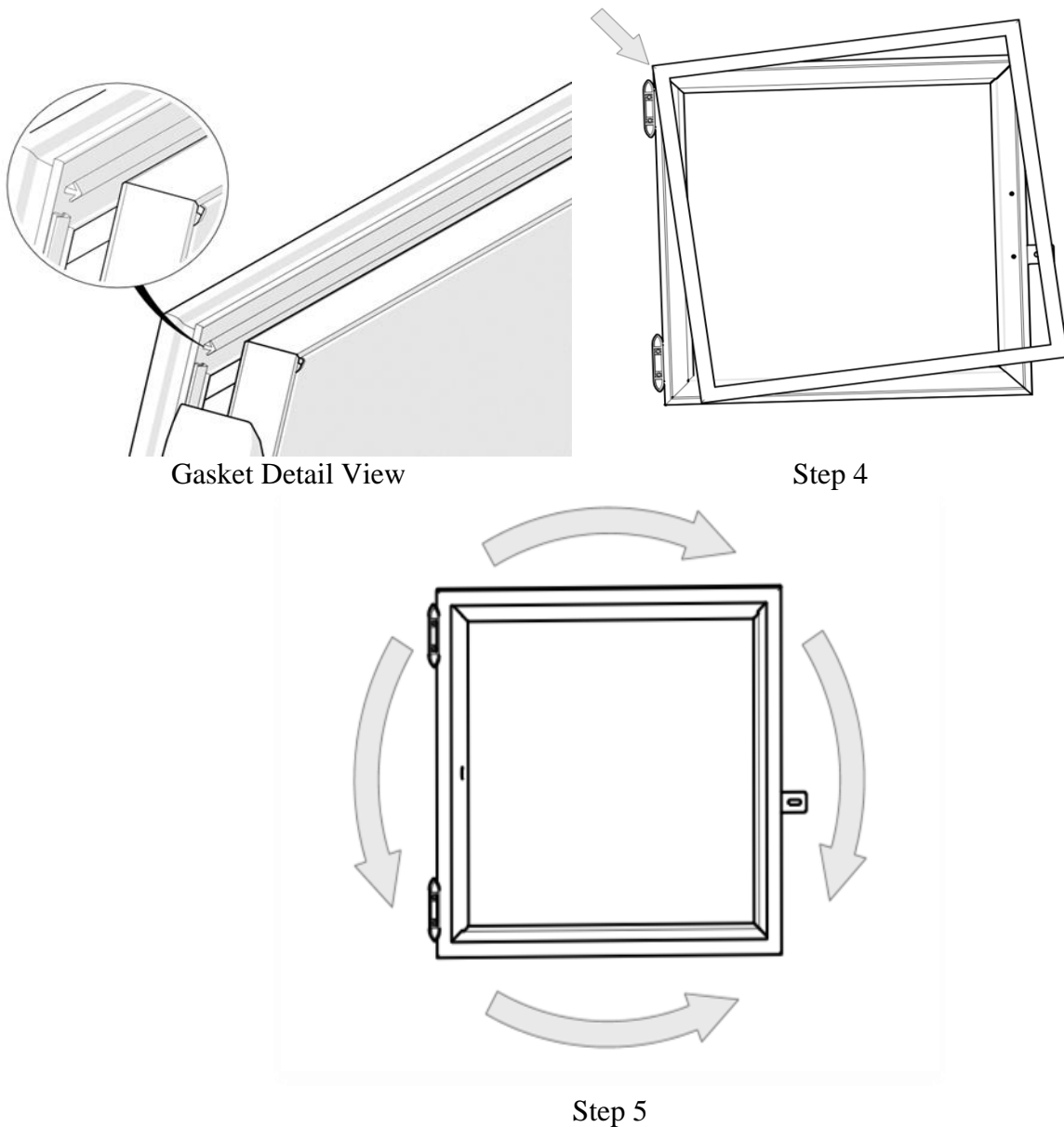
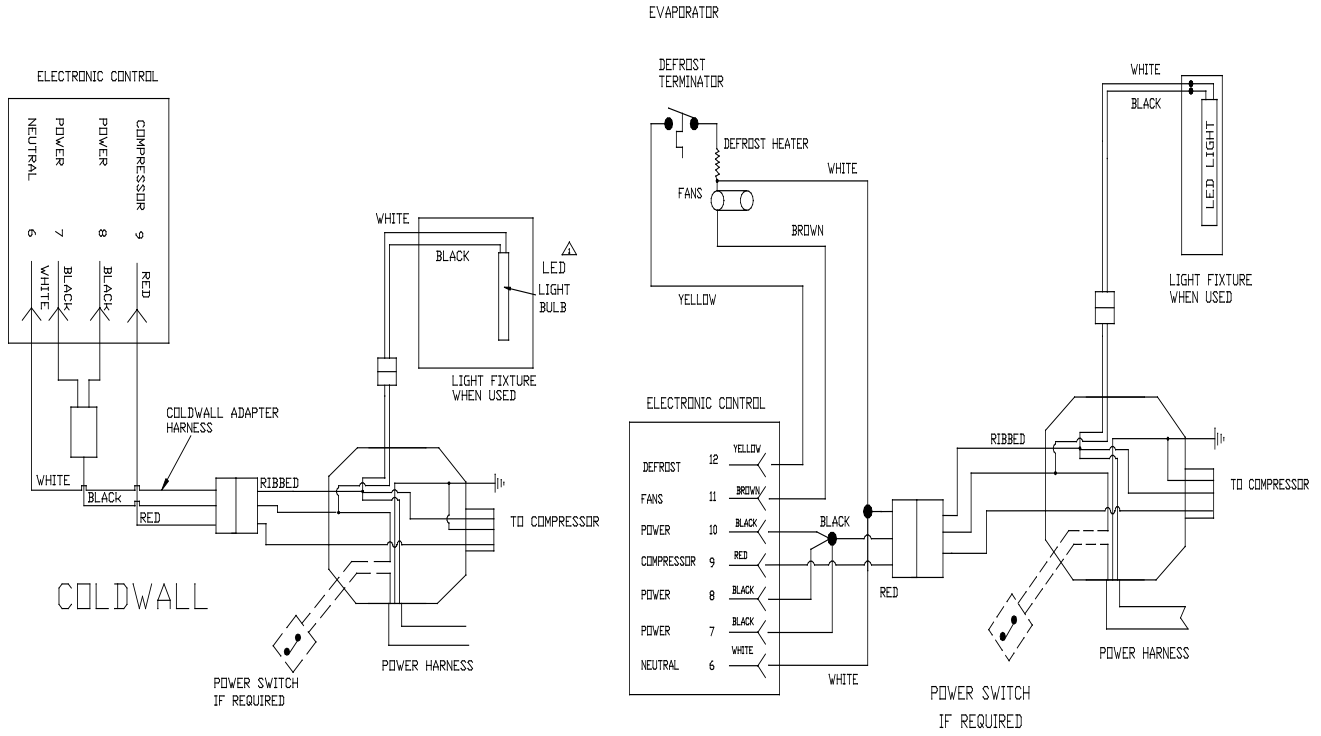
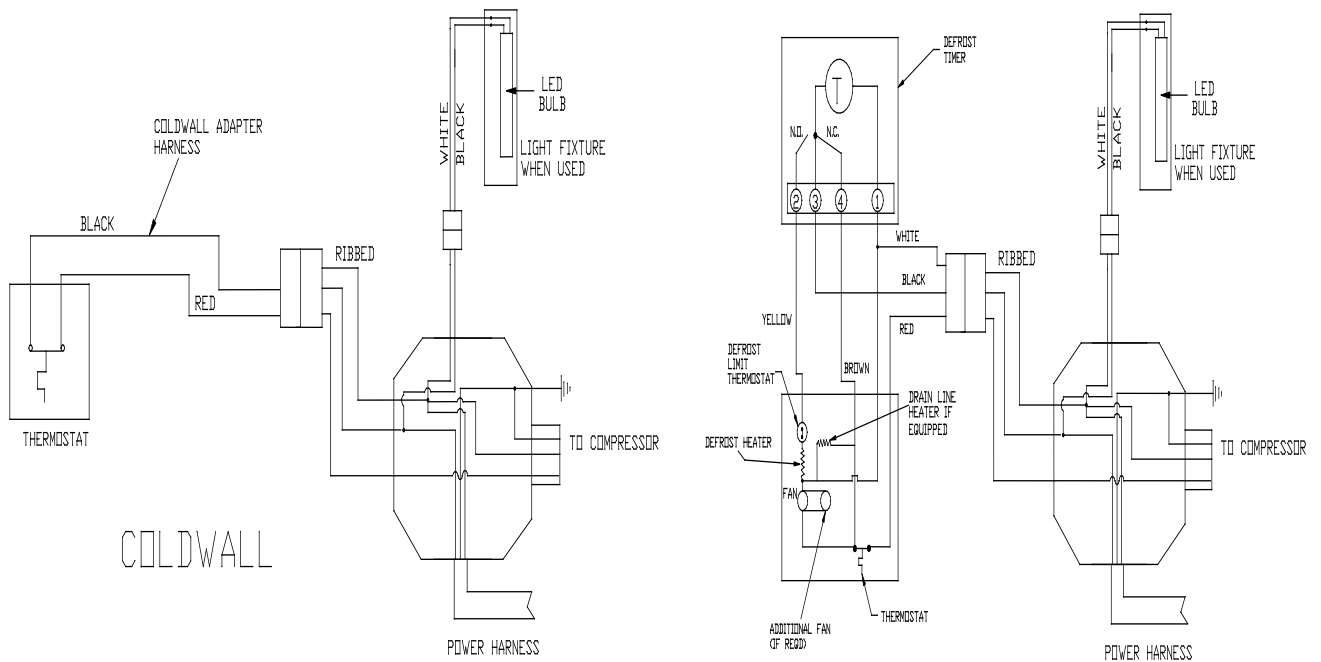

Figure 4: Door Gasket Install

Electronic Control- CW and AD Wiring Diagram



Mechanical Control- CW and AD Wiring Diagram



Replacement Parts List

<u>ITEM</u>	<u>DESCRIPTION</u>	<u>PART #</u>	<u>ITEM</u>	<u>DESCRIPTION</u>	<u>PART #</u>
1.	Condensing Unit: Provide condensing unit model number		12.	Door, Stucco Charcoal Gray 27" x 27" with gasket	5591027
2.	Thermostat - Mechanical	1328046	13.	Door Gasket for 27" x 27" solid door	1030016
	Timer - Mechanical	1328023	14.	Hinge with cover for 27" x 27" solid door	1911019
	Electronic Control – CW XRO2	1328034	15.	Door, Stucco Charcoal Gray 27" x 46" with gasket	5591035
	Electronic Control – AD XRO4	1328035	16.	Door Gasket for 27" x 46" solid door	1030014
	Sensor Probe Evap (Black)	1328055	17.	Glass Door, 28" x 47" Silver Frame	1412012
	Sensor Probe Room (Red)	1328056	18.	Door Gasket for 28" x 47" glass door	1490007
	Power Harness w/o Switch Terminal	1270062	19.	Door Hinge for 28" x 47" door: Silver w/spring & cover	1911002
	Power Harness with Switch Terminal	1270070		Silver Hinge Cover	1990008
	Toggle Switch (for PN 1270070)	1213042		Spring-Load Kit (Kason 220 hinge)	1990002
3.	Unit Cooler Evaporator Parts:		20.	"ICE" Decals (Red) One Set	1070074
	Fan Guard	1396023		"ICE" Decals (Blue) One Set	1070070
	Fan Blade	1392008	21.	Rain Shield for 27" x 46" solid door	5120098-5
	Fan Mounting Bracket	5120140	22.	Ice Pallet 22" x 28" Black	1050079
	Fan Motor	1393029	23.	LED lamp (2' T8 cool white clear)	1216009
	Mechanical Defrost Termination Switch 30/70F	1328003	24.	Condensate evaporator assy. for automatic defrost models (White)	5349040
	Electronic Defrost Safety Switch 70/100F	1328004	25.	Cond. evaporator heat element 125W	1261004
	LCL 120 Defrost Heater – 400W	1261007	26.	Merchandiser leveling kit 4 pc	5350029
	LCL 170 Defrost Heater – 600W	1261008			
	LCL 190/280 Defrost Heater – 800W	1261009			
4.	Full Top Enclosure: Provide the merchandiser model number.				
5.	"ICE" Decal for full top (Red)	1070076			
	"ICE" Decal for full top (Blue)	1070069			
6.	Cover w/o decal	5848004-5			
	Cover w/ decal	5848000-5			
7.	"Packaged Ice" Decal.	1070068			
8.	J-Bolt for all solid doors	1160008			
9.	Door Hasp for all solid doors	5120001			
10.	Door Handle for all solid doors	1914001			
11.	Check Chain	1915001			

Note: Providing the cabinet model and serial number will aid in identifying parts for a specific merchandiser.

Return authorized parts to this address:
Leer, Inc.
206 Leer St.
New Lisbon, WI 53950

- Contact Leer Merchandiser Customer Service Dept. to obtain a Return Material Authorization (RMA) Number.

NOTE: Leer electrical and refrigeration parts are installed in compliance to UL Standard 471. Replacement parts that are not UL Certified or are not identical to the OEM installed part, will void the merchandiser's UL Listing and/or the Factory warranty per "General Provisions" of the accompanying warranty statement.

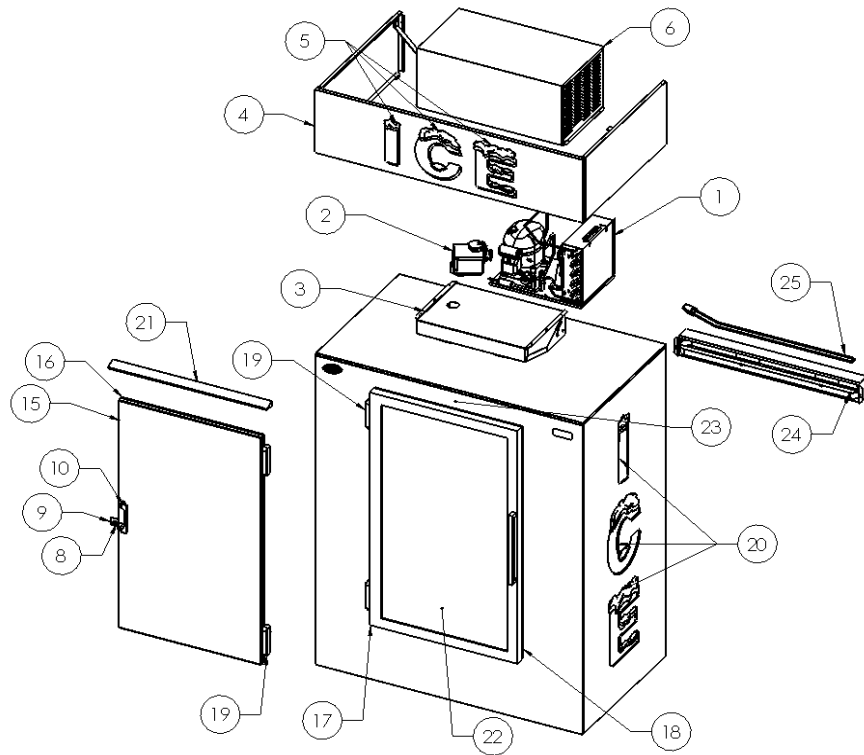

Upright Models

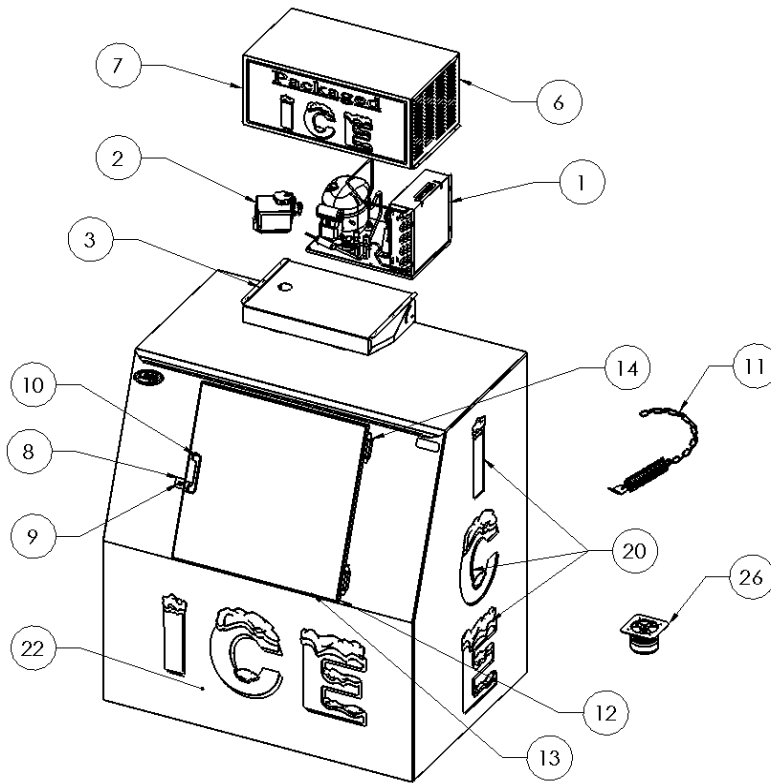

Slant Models

Note: LP models are similar in design to slant models except for refrigeration location.

Warranty

ICE MERCHANDISERS: Seller warrants the merchandiser under normal use and service, for one (1) year for the component parts (to be shipped by seller), and ninety (90) days for repair labor from the date of original shipment. The merchandiser compressor motor is warranted for five (5) years from the date of original shipment. SELLER MUST BE CONTACTED AND PROVIDED A MERCHANDISER SERIAL NUMBER FOR WARRANTY CLAIM. This applies only to goods installed in the United States, Canada or Mexico. Seller's obligation under this warranty shall be limited to repair (subject to the limitations below) or replacement of any part(s), F.O.B. Seller's factory, which prove(s) defective within the applicable warranty period. Seller reserves the right to inspect defective part(s) and may at Seller's discretion require return of part(s) to Seller's factory for inspection. The determination as to whether any defect exists shall be made in Seller's sole judgement.

GENERAL PROVISIONS APPLICABLE TO ALL WARRANTIES AND PRODUCTS: Seller shall not be liable for any breach of any express warranty set forth above unless Seller is informed immediately upon the discovery of defective part(s). The warranties described above are not assignable and shall operate only in favor of the original buyer/user. In event of any claim for breach of express warranty, Seller shall be responsible for labor charges for repair or replacement of any defective part(s) or assembly only for defects reported to Seller within ninety (90) days after the date of installation. ALL LABOR CHARGES SHALL BE AUTHORIZED OR APPROVED BY SELLER PRIOR TO THE REPAIR OR REPLACEMENT OF PART(S). In all other events, Seller shall not be responsible for any labor charges. Labor charges shall only include standard straight time labor hours at the site of product installation, and shall exclude charges for travel time, mileage, or other premium charges. These warranties shall not apply to any goods, or any part thereof, which may have been subject to any damage in transit, accident, negligence, abuse or misuse, unauthorized alteration or repair, acts of nature or failure to follow any of the Seller's manuals or instructions, if in Seller's sole judgement, such act, omission or event has detrimentally affected the physical condition, use or operating qualities of the product.

SELLER MAKES NO WARRANTY, EXPRESS OR IMPLIED, BY REASON OF LAW, STATUE OR OTHERWISE, INCLUDING ANY IMPLIED WARRANTY OF MERCHANTABILITY OR FITNESS FOR A PARTICULAR USE OR PURPOSE, AND ALL IMPLIED WARRANTIES ARE HEREBY DISCLAIMED. SELLER SHALL NOT BE LIABLE FOR LOSS OF GOODS, MERCHANDISE OR OTHER PROPERTY, OR LOSS OF PROFITS, RESULTING FROM PRODUCT DEFECTS. IN NO EVENT SHALL SELLER'S LIABILITY UNDER ANY CIRCUMSTANCES FOR ANY BREACH OF CONTRACT OR FOR ANY OTHER CLAIM BY BUYER AGAINST SELLER EXCEED THE CONTRACT PRICE OF THE GOODS SOLD HEREUNDER WITH RESPECT TO WHICH SUCH CLAIM ARISES.

MODEL NO. _____

SERIAL NO. _____